

SPAR PRESSURE INDICATOR
(UNSAFE SHOWN)

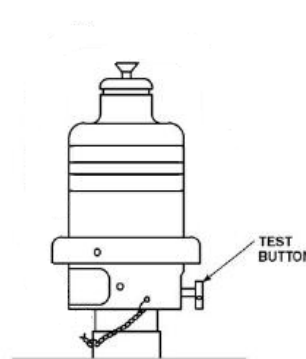

SPAR PRESSURE INDICATOR
(SAFE SHOWN)

IBIS (In-Flight Blade Inspection System)

Radiation Hazard Awareness and Permit Requirements Training

Elisabeth Holland, MSPH, CIH

NAVAIR 09F/7.10.1

February 2009

IBIS Radiation Course

Objectives:

- Learn about the IBIS
- Understand IBIS radiation
- Know how to prevent exposure to radiation from the IBIS
- Understand IBIS Material License requirements
 - Safety
 - Shipping
 - Leak Testing
 - What to do if exposure to,

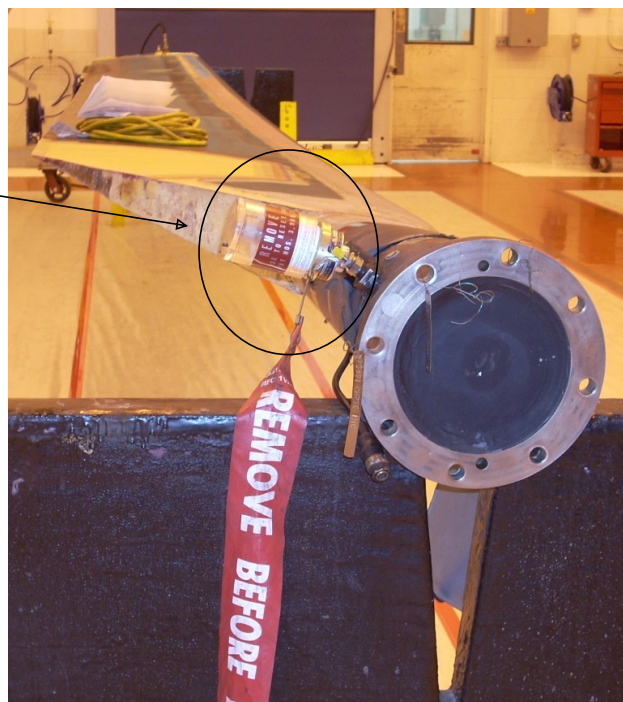

lost, stolen, or missing IBIS

- Document posting requirements



What is an IBIS Device?

- IBIS is a device that provides in-flight warning of blade failure on CH/MH-53 A,C,D&E helicopters
- Part numbers:
 - 12210-1
 - 12220-1
- NIIN:
 - 01-125-8904: (CH/MH)
 - 01-265-3656: (CH-53D)
- Cover part number:
 - 12239-1
- Cover NIIN:
 - 01-160-3748
 - 01-125-0659
- Contains sealed radioactive source (Strontium-90)

What is an IBIS device?

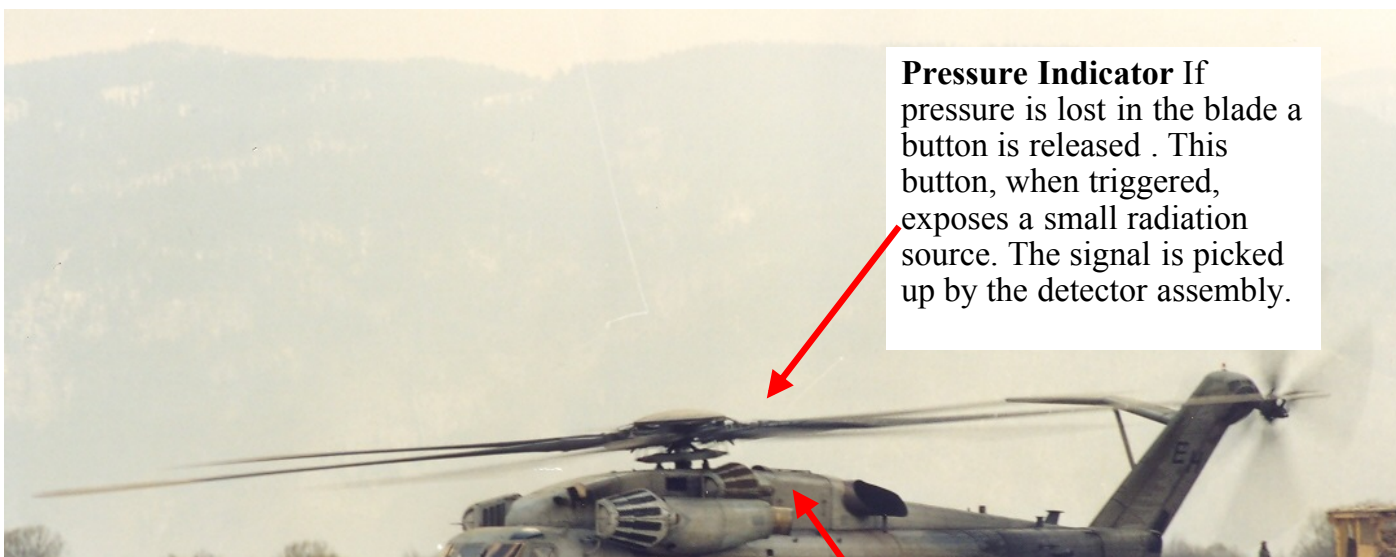



Signal Processor The signal processor picks up the message which illuminates the master caution lights on cockpit panel.

Detector Assembly Picks up radiation signal from the pressure indicator and sends a signal to the signal processor.

What is an IBIS Device?

- The radiation source is in shielded (safe) condition when blade pressure is normal and IBIS is installed
- Emits radiation only when blade loses pressure, by pressing the manual test button, or removing the IBIS from the blade.
- Shown with protective cover that shields (protects) from radiation

IBIS Indicator – Source inside Shield

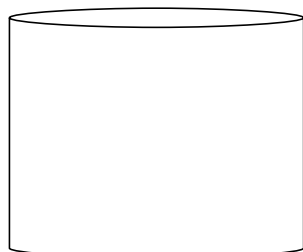

← Shipping cover - absorbs radiation from the source

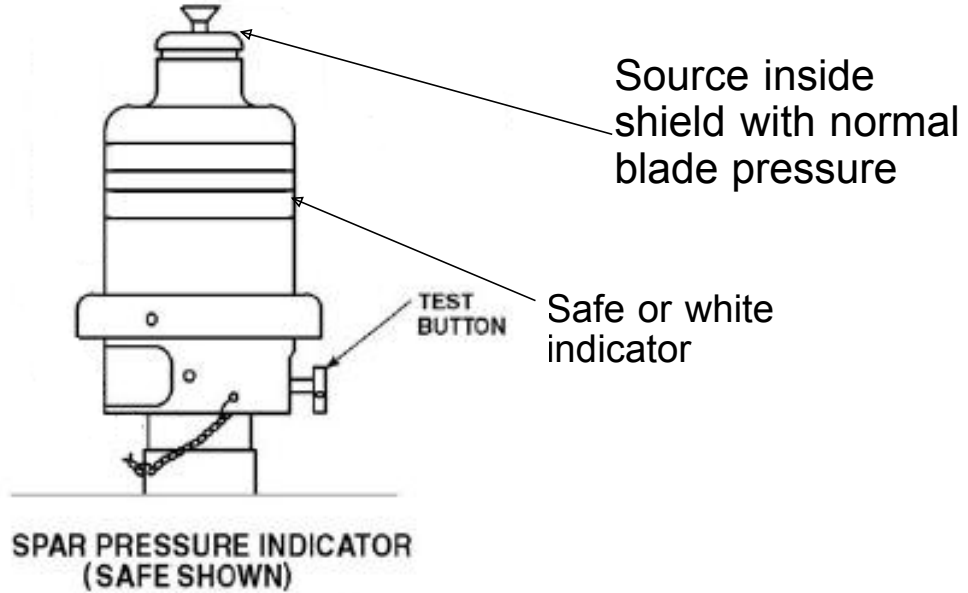

IBIS Indicator – Source out of Shield

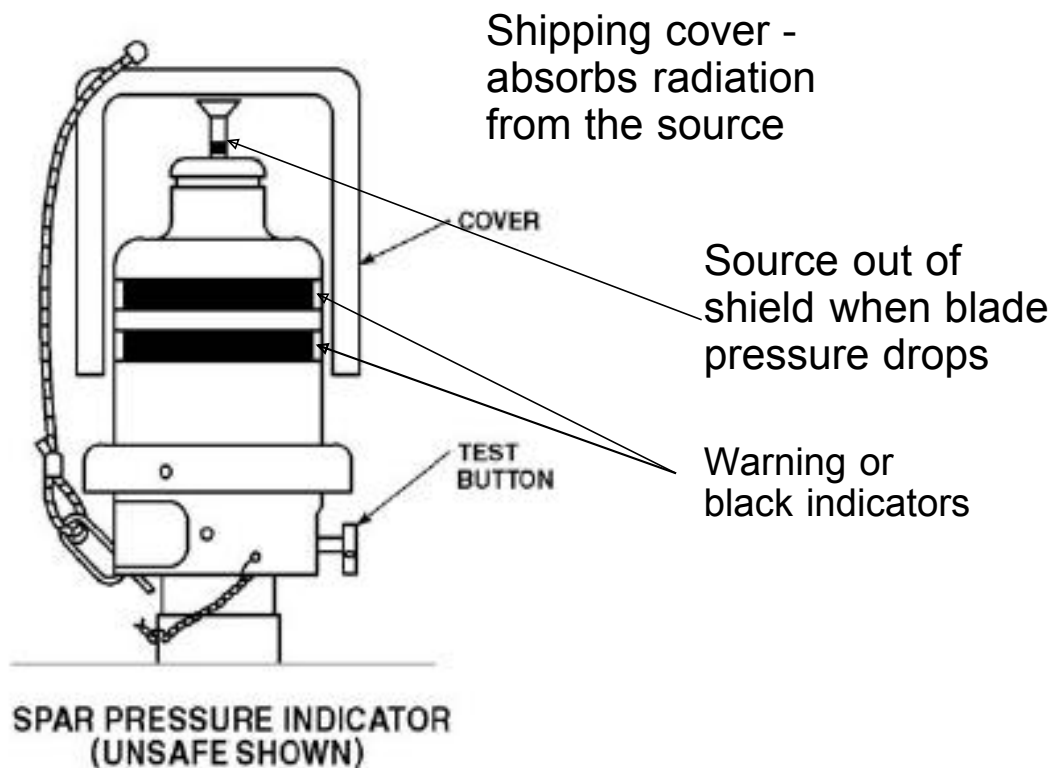

IBIS Devices

- The Navy and Marines can use IBIS devices under Naval Radioactive Materials Permit No. 19-00019-T5NP and NAVAIR Instruction 5104.1
- Must follow the permit requirements
 - Failure to follow requirements could result in:
 - Personnel exposure to radiation
 - Fines or suspension of the permit
 - Suspension of the permit would ground affected aircraft

IBIS Safety and Permit Requirements

White Bands Visible=Safe

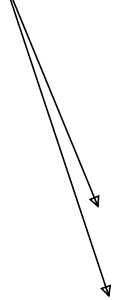

- IBIS without cover
- When indicator is normal position (blade pressurized) white bands are visible.
- Strontium 90 source is inside a shield that absorbs nearly all radiation

Note: For illustrative purposes only. All IBIS must have protective covers installed except when ready for flight

IBIS Safety and Permit Requirements

Black Bands = Warning



- IBIS device showing black (depressurization)
- Exposure hazard exists when the blade has lost pressure, the self test button is activated, or the IBIS is removed from the blade.
- The Strontium 90 source is out of its shield and beta radiation is emitted in a 360° “doughnut” pattern around the end of the indicator.
- Reset button on top (should only be used in conjunction with protective cover)
- A shipping cover is provided with each indicator, which absorbs nearly all the radiation from the source

Note: For illustrative purposes only. All IBIS must have protective covers installed except when ready for flight

IBIS Safety and Permit Requirements

- Use the correct cover. Cover must be properly installed.
- Ensure cover is secured to pressure indicator with cable and one of the three holes on base of indicator
- Wear leather gloves and eye protection (safety glasses, goggles, or face shield) during IBIS testing and handling IAW appropriate manual
- Stay at least 6 inches from IBIS indicator whenever possible



IBIS Safety and Permit Requirements

- The protective cover must be on the indicator at all times except when helicopter is on flight line in “up status”
- The protective cover must be on the indicator anytime a blade with IBIS is:
 - serviced
 - removed
 - installed
 - tested
 - checked
 - transported
 - shipped
- This cover must be in place at all times when IBIS is not on blade



IBIS Safety and Permit Requirements

- Make sure IBIS show white before entering area of rotor head for any reason
- Before inspection or maintenance work, install protective cover on each IBIS near work area
- **Do not use IBIS indicator as a handhold.** Any bending or side load put on indicator or on installed protective cover will seriously damage indicator, which

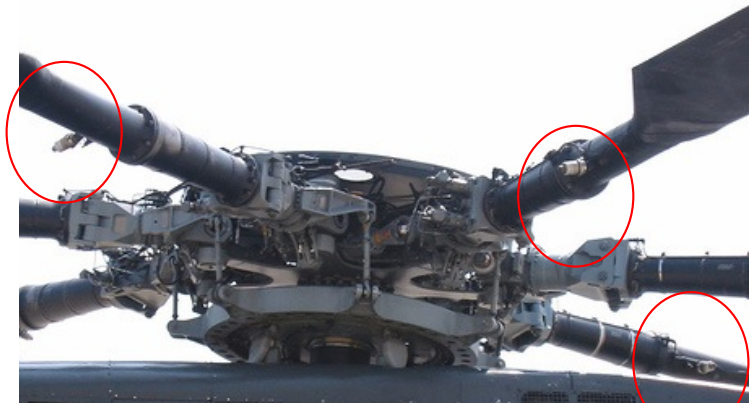

can cause IBIS system to fail to warn of a cracked or malfunctioning blade, should one develop.



IBIS Safety and Permit Requirements

- If pressure indicator shows black **with** a protective cover:
 - Wear leather gloves and eye protection (safety glasses, goggles, or face shield) IAW A1-H53CE-150-200.
 - Do not handle the indicator and prevent exposure within 6 inches
 - Press firmly on protective cover to reset IBIS indicator but do not strike or use excessive force
 - IBIS indicator may need to be replaced if it cannot be reset



IBIS Safety and Permit Requirements

- If pressure indicator shows black **without** a protective cover:
 - Restrict access to area of IBIS indicator
 - Use "Caution Radioactive"

Material" barrier tape with perimeter of 10 feet from source

- Only personnel with radiation training specific to the IBIS should attempt to put a cover on the indicator and reset
- Wear leather gloves and eye protection (safety glasses, goggles, or face shield)
- When approaching indicator that shows black, keep eyes at least 24 inches from indicator and do not exceed one minute near indicator



Note: For illustrative purposes only. All IBIS must have protective covers on except when ready for flight

IBIS Safety and Permit Requirements

- Should pressure indicator fail to operate properly or be damaged, or should there be any indication of failure or damage, remove covered indicator from service immediately IAW appropriate manual.
- Store indicator with protective cover installed in a secure area until disposition has been arranged.
- If IBIS indicator becomes damaged, seal IBIS indicator and protective cover in plastic bag before it is packaged for shipping. Include swab from wipe test (IAW appropriate manual) and contaminated gloves if applicable, in separate plastic bags.
- Shipping of one or more indicators is to be done in accordance with NAVSUPINST 3400.5. Master Repairable Items List (MRIL).



Note: Protective cover is required to be installed on IBIS before putting in shipping container

IBIS Safety and Permit Requirements

- If IBIS device is damaged or falls off the aircraft:
 - Attempt to locate the device
 - If the IBIS is located, shield the IBIS with a protective cover and determine if the radioactive source is still on the device
 - Use following pictures as references

IBIS Strontium 90 Source (500uCi)

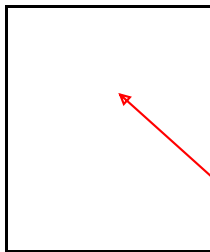
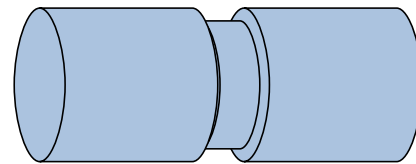

~0.476 inches

Radioactive
Source

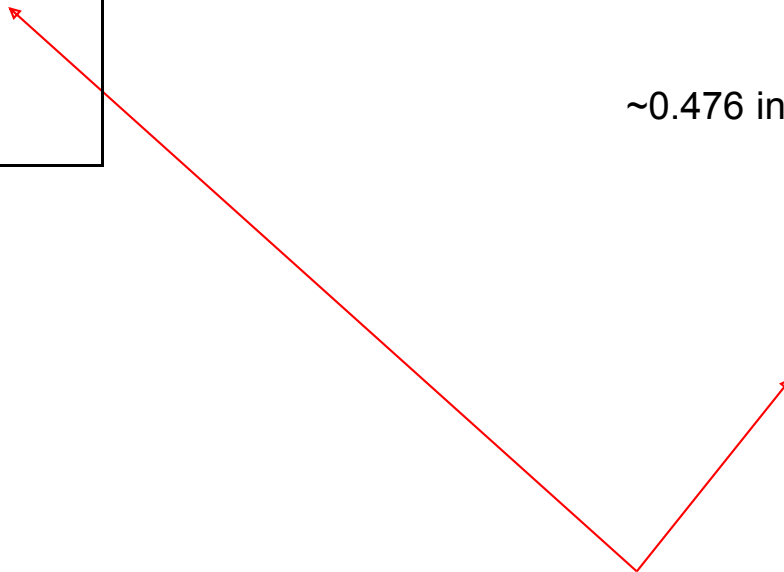



IBIS Safety

- If there is a mishap, crash, rescue, and recovery personnel need to be informed about the presence of and plan for protection from the radioactive hazard from IBIS
- Contact NAVAIR at 301 757-2133 for more guidance





IBIS Safety and Permit Requirements

- IBIS indicators must be tested for leakage or contamination at the time of installation and at six month intervals.
- No need to leak test IBIS in storage
- Do need to leak test when removed from storage if not checked within 6 months
- There are special shipping procedures for IBIS devices

References for IBIS Safety and Permit Requirements

Refer to the following for additional requirements and proper procedures for leak tests and shipping:

- *CH-53D Aircraft*
 - **A1-H53AD-150-000** ORGANIZATIONAL MAINTENANCE, MAINTENANCE PROCEDURES, ROTOR SYSTEMS NAVY MODEL CH-53D
 - **WP 004 00** ORGANIZATIONAL MAINTENANCE, ROTARY WING BLADES
 - **WP 004 01** INTERMEDIATE MAINTENANCE, ROTARY WING BLADES
 - **WP 005 00** ORGANIZATIONAL MAINTENANCE, MAINTENANCE BIMR/IBIS WARNING SYSTEM
- *CH-53E and MH-53E Aircraft*
 - **A1-H53CE-150-000** ORGANIZATIONAL MAINTENANCE, MAINTENANCE PROCEDURES, ROTOR SYSTEMS NAVY MODELS CH-53E AND MH-53E

- **WP 003100** ORGANIZATIONAL MAINTENANCE, MAINTENANCE PROCEDURES, ROTARY WING BLADES (More useful information on the indicators than WP 045 00)
- **WP 045 00** ORGANIZATIONAL MAINTENANCE, MAINTENANCE PROCEDURES, COCKPIT-IN-FLIGHT BLADE INSPECTION SYSTEM
- **A1-H53CE-150-200**
 - WP 003 00 TESTING AND TROUBLESHOOTING PROCEDURES IN-FLIGHT BLADE INSPECTION SYSTEM (IBIS)

IBIS Safety and Permit Requirements

- Notify NAVAIR 7.10.1 within 24 hours (or next weekday) at (301) 757-2133 of any of the following:
 - Potential personnel exposure to radiation from IBIS (showing black without cover)
 - Theft or loss of IBIS (including loss of aircraft with IBIS)
 - Loss of radiation source from an IBIS

IBIS Safety and Permit Requirements

- Posting Requirements-Where IBIS are used or stored, the following shall be posted:
 - NRC Form 3
 - Copy of the IBIS permit

- Any notice of violation issued by the Navy Radiological Affairs Support Office (RASO) or the Nuclear Regulatory Commission (NRC)
- Documents are available at Mission/Occupational Safety and Health page at <https://home.navair.navy.mil/safety/index.cfm>

Summary

- Keep cover on IBIS at all times when not ready for flight
- Follow shipping procedures
- Radiation exposure levels are highest when the IBIS indicator is not properly covered and the black indicators are showing
- Remember to keep the IBIS indicator cover on and work at least 6 inches from the source, as much as possible
- Follow instructions in manuals
- Report potential exposures to, loss or theft of IBIS